



## CSN® SCREW-IN HEATER FOR WATER WARMING STAINLESS STEEL VERSION WITHOUT THERMOSTAT

### Application:

heating of water normal quality max. 100°C, max. 10 bar;

### Mounting position:

horizontal

material 1.4404 brass screw-in nipple S.P. thread 1½"

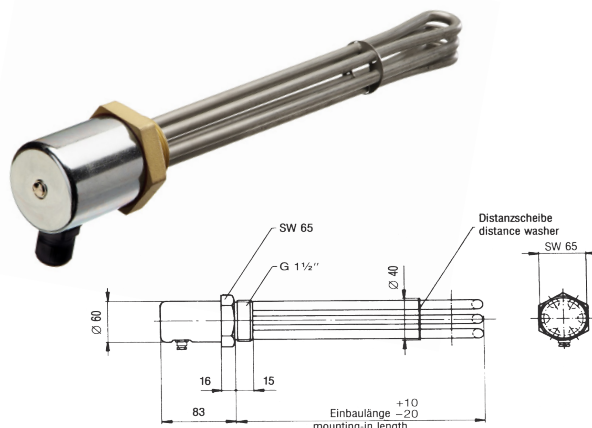

with hood IP 54 type	mounting-in length 35 mm unheated	voltage volts	capacity watts	surface load W/cm2	weight with hood kgs
ERCH / 20	200	400 3N~	1500	5,9	0,75
ERCH / 25	250	400 3N~	2000	6,0	0,85
ERCH / 35	350	400 3N~	3000	6,0	1,05
ERCH / 45	450	400 3N~	4500	6,9	1,20
ERCH / 65	650	400 3N~	6000	6,2	1,55
ERCH / 65	650	400 3N~	9000	9,2	1,55
ERCH / 80	800	400 3N~	9000	7,4	1,85

Stock type

## WITH THERMOSTAT

material 1.4404

brass screw-in nipple S.P. thread 1½"

with thermostat 0–85°C oder 30–110°C 1 pol.

By three-phase connection a contactor has to be considered.

A three-phase controller for direct switching can be used till 9 kW

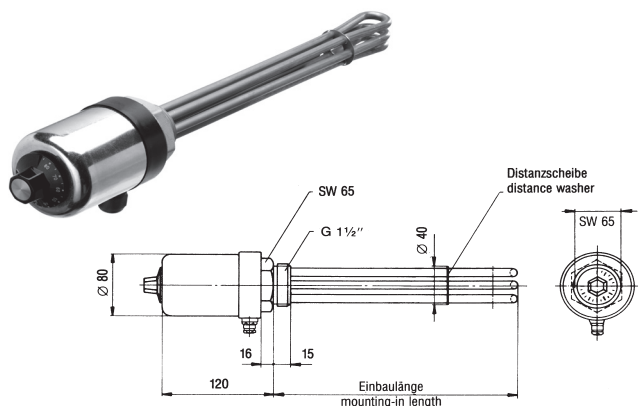

with hood IP 54, type	mounting-in length 35 mm unheated	voltage volts	capacity watts	surface load W/cm2	weight kgs
ERCT / 20	200	400 3N~	1500	5,9	1,55
ERCT / 25	250	400 3N~	2000	6,0	1,65
ERCT / 35	350	400 3N~	3000	6,0	1,80
ERCT / 45	450	400 3N~	4500	6,9	2,00
ERCT / 65	650	400 3N~	6000	6,2	2,30
ERCT / 65	650	400 3N~	9000	9,2	2,30
ERCT / 80	800	400 3N~	9000	7,4	2,60

Stock type

## Special requirements on request!

### Specialist contact person:

#### Bernd Tigges

Phone: +49 2392 - 692 - 42  
Fax: +49 2392 - 692 - 8942  
eMail: bernd.tigges@schniewindt.de

#### Stephan Drüeke

Phone: +49 2392 - 692 - 43  
Fax: +49 2392 - 692 - 8943  
eMail: stephan.drueeke@schniewindt.de