



CSN® SCREW-IN HEATER FOR WATER WARMING COPPER PLATED VERSION WITHOUT THERMOSTAT

Application:

heating of water normal quality max. 100°C, max. 10 bar;

Mounting position:

horizontal

material copper nickel plated, brass screw-in nipple S.P.

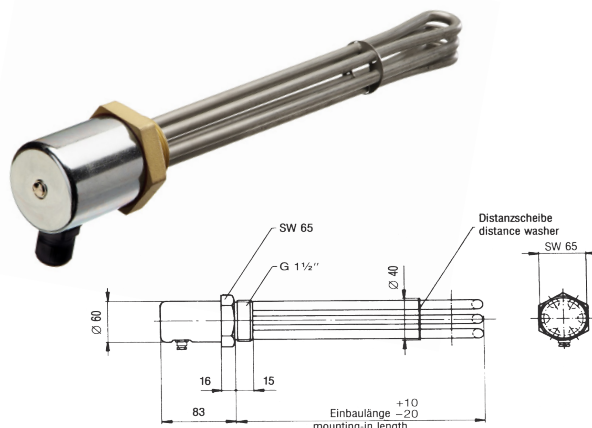

with hood IP 54,type	mounting-in length 35 mm unheated	voltage volts	capacity watts	surface load W/cm ²	weight with hood kgs
ERKH / 20	200	400 3N~	2000	7,8	0,80
ERKH / 25	250	400 3N~	2500	7,4	0,90
ERKH / 30	300	400 3N~	3000	7,2	1,00
ERKH / 35	350	400 3N~	3500	7,1	1,05
ERKH / 40	400	400 3N~	4500	7,8	1,15
ERKH / 45	450	400 3N~	6000	9,1	1,25
ERKH / 55	550	400 3N~	7500	9,2	1,40
ERKH / 65	650	400 3N~	9000	9,2	1,55

Stock type

WITH THERMOSTAT

material copper nickel plated

brass screw-in nipple S.P. thread 1½"

with thermostat 0–85°C oder 30–110°C 1 pol.

By three-phase connection a contactor has to be considered.

A three-phase controller for direct switching can be used till 9 kW

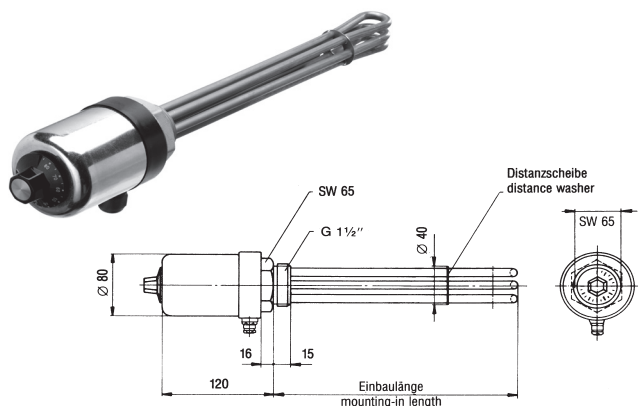

with hood IP 54, type	mounting-in length 35 mm unheated	voltage volts	capacity watts	surface load W/cm ²	weight kgs
ERKT / 20	200	400 3N~	2000	7,8	1,55
ERKT / 25	250	400 3N~	2500	7,4	1,65
ERKT / 30	300	400 3N~	3000	7,2	1,75
ERKT / 35	350	400 3N~	3500	7,1	1,80
ERKT / 40	400	400 3N~	4500	7,8	1,90
ERKT / 45	450	400 3N~	6000	9,1	2,00
ERKT / 55	550	400 3N~	7500	9,2	2,15
ERKT / 65	650	400 3N~	9000	9,2	2,30

Stock type

Special requirements on request!

Specialist contact person:

Bernd Tigges

Phone: +49 2392 - 692 - 42
Fax: +49 2392 - 692 - 8942
eMail: bernd.tigges@schniewindt.de

Stephan Drüeke

Phone: +49 2392 - 692 - 43
Fax: +49 2392 - 692 - 8943
eMail: stephan.drueeke@schniewindt.de